

Deluxe Salt/Pepper Shakers

william wood-write

penblanks.ca



Needed:

Mandrel A (7mm), 32mm forstner bit, bushing 110A

Preparing the blanks

1. Square and cut a blank 2" x 2" x 2 1/2". Be sure all sides and ends are square.
2. Using a drill press, clamp the blank in a vise and drill a 32mm hole 2 1/4" deep. Don't exit the bottom of the blank. It is important to be sure you are drilling square to the face of the blank so that the kit parts will fit without gaps.
3. Trim the end of the blank so the drill hole is exposed, close to the 2" length needed for the chrome tube. Make sure to make a square cut.
4. Dry fit the chrome tube into the blank. It will likely be a tight fit. Using 80 grit sandpaper, scuff out the inside of the hole a small amount until the chrome tube fits in smoothly.
5. Scuff the outside of the chrome tube with 220 grit sandpaper for better glue adhesion.
6. Plug the ends of the tube with baseplate wax to keep glue from going inside of the tube.
7. Roll the tube in glue and insert into the blank and set aside for the glue to cure.
8. Remove the baseplate wax and trim the ends of the blank **square to the tube** on a disk sander.
9. **DO NOT TRIM THE CHROME TUBE. If the tube is shortened the shaker parts will not fit properly.**

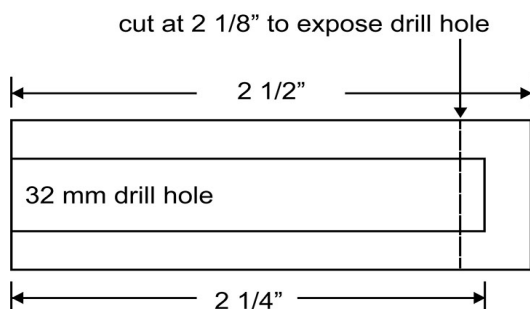

Turning the blanks

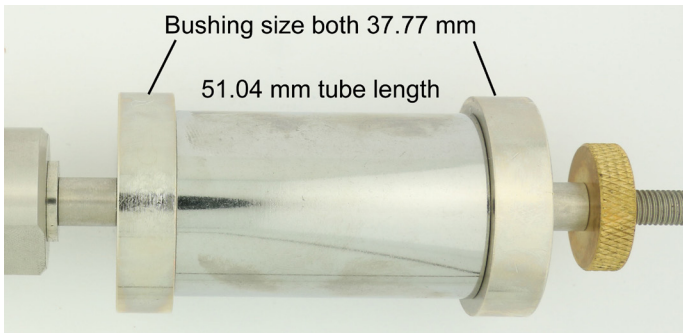

1. Put the bushings and barrel onto the mandrel referring to the image above.
2. Lightly tighten the tailstock to the mandrel. Do not over-tighten the tailstock to the end of the mandrel as this can bend the mandrel.
3. Turn the barrel to the desired shape using the bushings as a sizing guide.
4. After turning the blank, sand the surface in progressive steps until you get to 600 grit. For an extra smooth finish, continue sanding with Micro Mesh through to 12,000 grit. Apply a finish of your choice.

Assembling the shakers

1. Press the bottom end cap into the blank.
2. Place the plastic cup, open side up, into the top of the barrel and seat it into the bottom of the end cap.
3. Press the threaded insert into the top of the barrel.
4. Screw on the shaker cap.

Tips to remember:

- Accuracy is key when drilling and when squaring the ends of the blank.
- Don't trim the chrome tube. If you do, the shaker parts will not fit properly.

